

# Instructions for installing your new wireless modem.

## Step One: Disconnect your old modem

- Turn off your computer.
- Unplug power adapter (B) from modem and electrical wall outlet.
- Disconnect coaxial cable (A) from back of modem
- Disconnect Ethernet cable (C) from back of modem.
- Disconnect Ethernet cable (C) from back of computer.

## Step Two: Install your new wireless modem

- Connect one end of the coaxial cable (A) to the cable wall outlet.
- Connect the other end of the coaxial cable (A) to modem.
- Connect one end of the new Ethernet cable (C) to the back of the modem (You can eliminate this step if connecting to a laptop computer for wireless connection.)
- Connect the other end of the new Ethernet cable (C) to the port of the computer. (You can eliminate this step if connecting to a laptop computer for wireless connection.)
- Plug in the new cable modem power adapter (B) into the cable modem.
- Plug in the new cable modem power adapter (B) into the electrical wall outlet.  
*Important: use only the power adapter that is supplied with the new cable modem.*
- Allow 2-5 minutes for the cable modem to connect to Midcontinent's network. Once the Power, Ethernet, Sync and Ready lights are solidly lit, the cable modem is successfully installed.
- Restart your computer.
- Open your Internet browser and visit [www.midcocomm.com](http://www.midcocomm.com) to test your Internet connection.

## Troubleshooting

If modem lights do not come on or you are having problems connecting to the Internet:

- Turn off your computer.
- Unplug the modem from the electrical wall outlet. If applicable, unplug other networking equipment, such as a router.
- Wait 15 seconds and plug the modem back in to the electrical wall outlet. If applicable, plug in other networking equipment such as a router.
- Restart your computer.
- Open your Internet browser and visit [www.midcocomm.com](http://www.midcocomm.com) to test your Internet connection.

## Instructions for logging on to the wireless connection

- Click START on your computer.
- Select SETTINGS.
- Select NETWORK CONNECTIONS.
- Select WIRELESS NETWORK CONNECTION.
- Select the wireless network that contains the last four digits of the RF MAC Address listed located on the bottom of the modem. Example: RF MAC Address is 00242B76ABCD; ABCD would be the last four digits.
- Enter the network key which is the entire cable RF MAC Address plus 14 zeros.  
NOTE: All upper case alpha characters in the address must be entered in lower case.  
Example, 0024b76abcd0000000000000000.
- Click CONNECT.

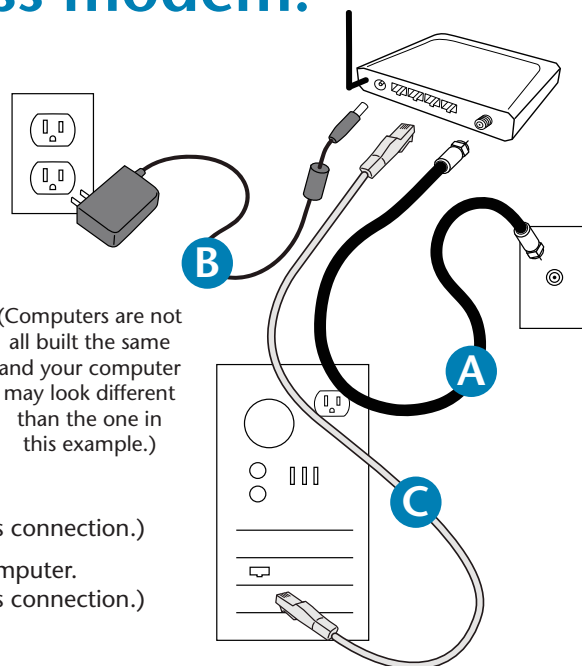

## Wireless Installation Components:

- Wireless Modem
- A. Coaxial Cable
- B. Cable Modem Power Supply
- C. Ethernet Cable

*If you are still experiencing problems after completing the troubleshooting steps, please call us at 1-800-888-1300 for assistance.*